

Foundations of Telecommunications Technology

Douglas C. Sicker

Department of Computer Science
Interdisciplinary Telecommunications Program
University of Colorado at Boulder

Purpose

- Consider the types of traditional networks
- Explore the technology trends
- Examine the implications of these technology trends

Understanding the T/C Industry

Understanding the T/C Industry

- Major Segments of the Industry (now blurred)
 - Telephone Companies (Local and Long Haul)
 - Data Communications Providers
 - Cable Television Companies
 - Commercial Mobile Radio Service Providers
 - Internet (and Enhanced) Service Providers
 - “Over-the-Air” Broadcasters
 - Equipment Manufacturers
 - Content Providers

Understanding the T/C Industry

- Characteristics of Different Types of Signals

	<u>VOICE</u>	<u>DATA</u>	<u>VIDEO</u>
Basic Signal Type:	Analog	Digital	Analog
Bandwidth:	Few KHz	Variable	MHz
Holding Times:	Minutes	Varies Widely	Minutes/hours
Activity:	“Continuous”	Bursty	Continuous
Delay Tolerance:	Very Little	Seconds	Seconds +
Symmetry:	Symmetrical	Asymmetrical	Asymmetrical

Traditional Network Architectures

Understanding the T/C Industry

- Traditional Network Architectures (the “Silos”)
 - Traditional Public Switched Telephone Network (PSTN)
 - Traditional Cable Television Network
 - Traditional Wireless Network
- Evolution of Traditional Networks (Convergence)
- Public Policy Implications (Illustrative)

The Traditional PSTN

- Access Perspective

IXC = Interexchange Carrier
POP = Point of Presence
FDI = Feeder-Distribution Interface
PBX = Private Branch Exchange
CPE = Customer Premises Equipment

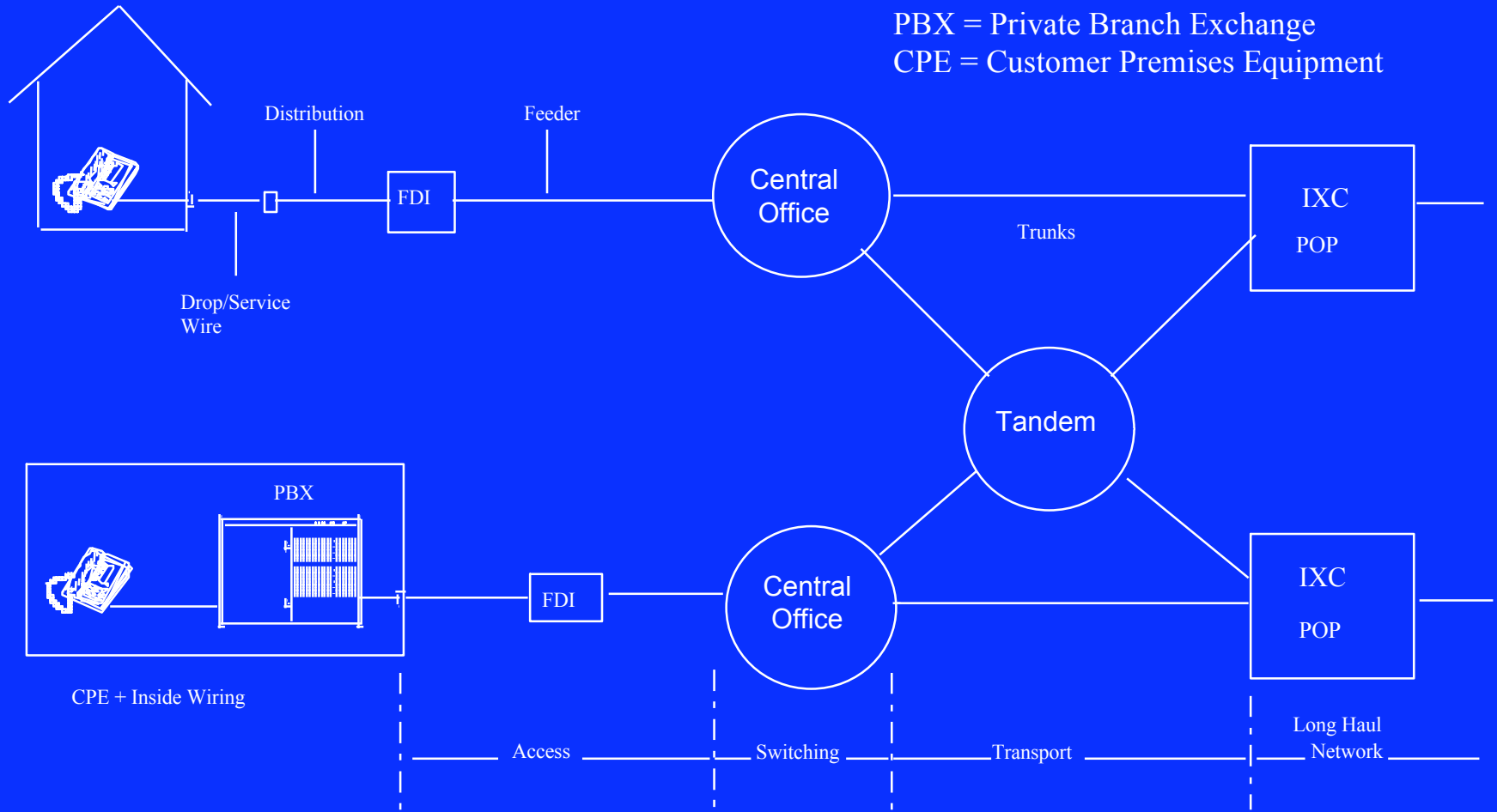

The Traditional PSTN

- Local Exchange Network from a Long Distance Access Perspective

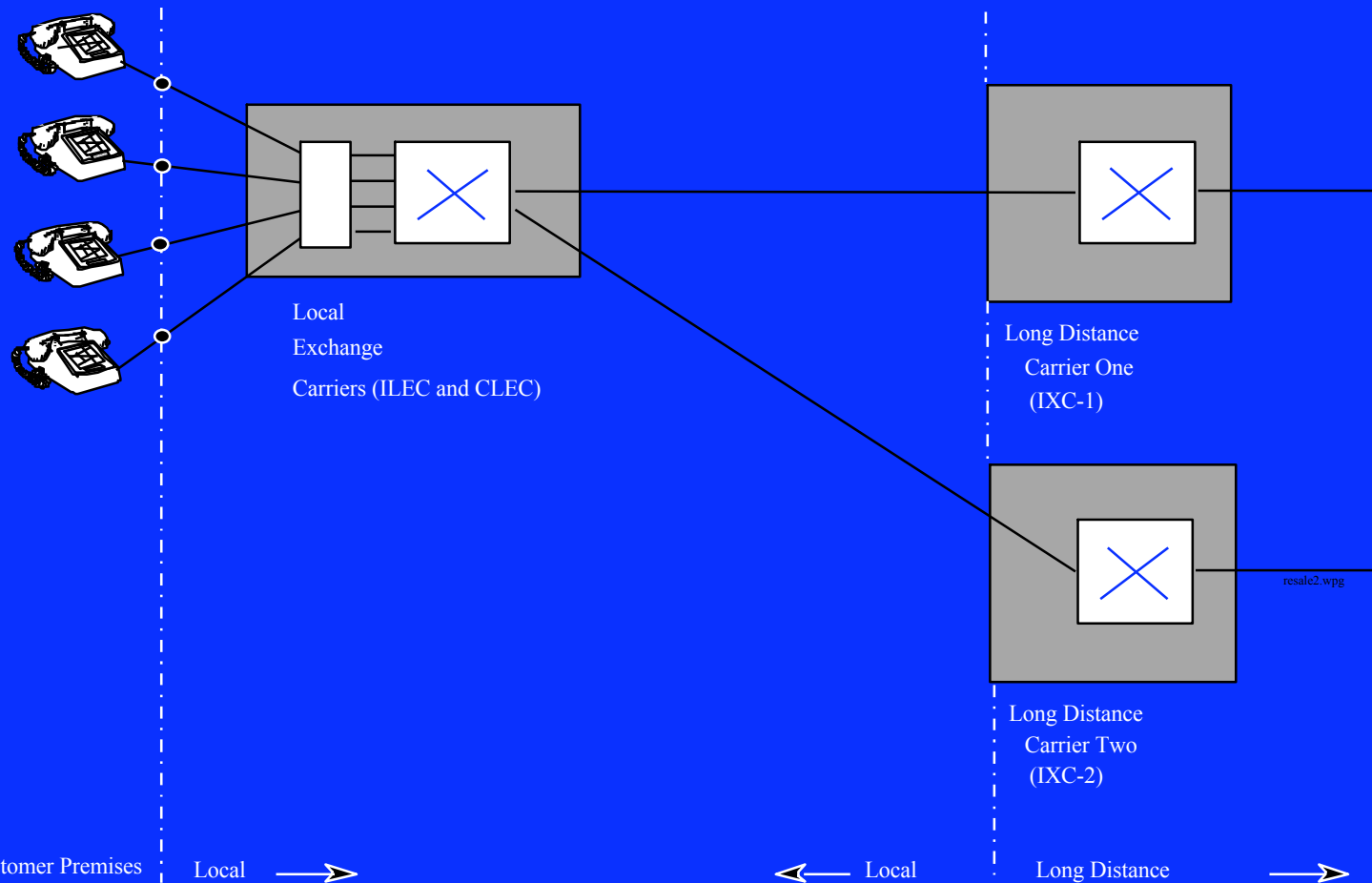

The Traditional PSTN

- Resale-Based Local Exchange Competition

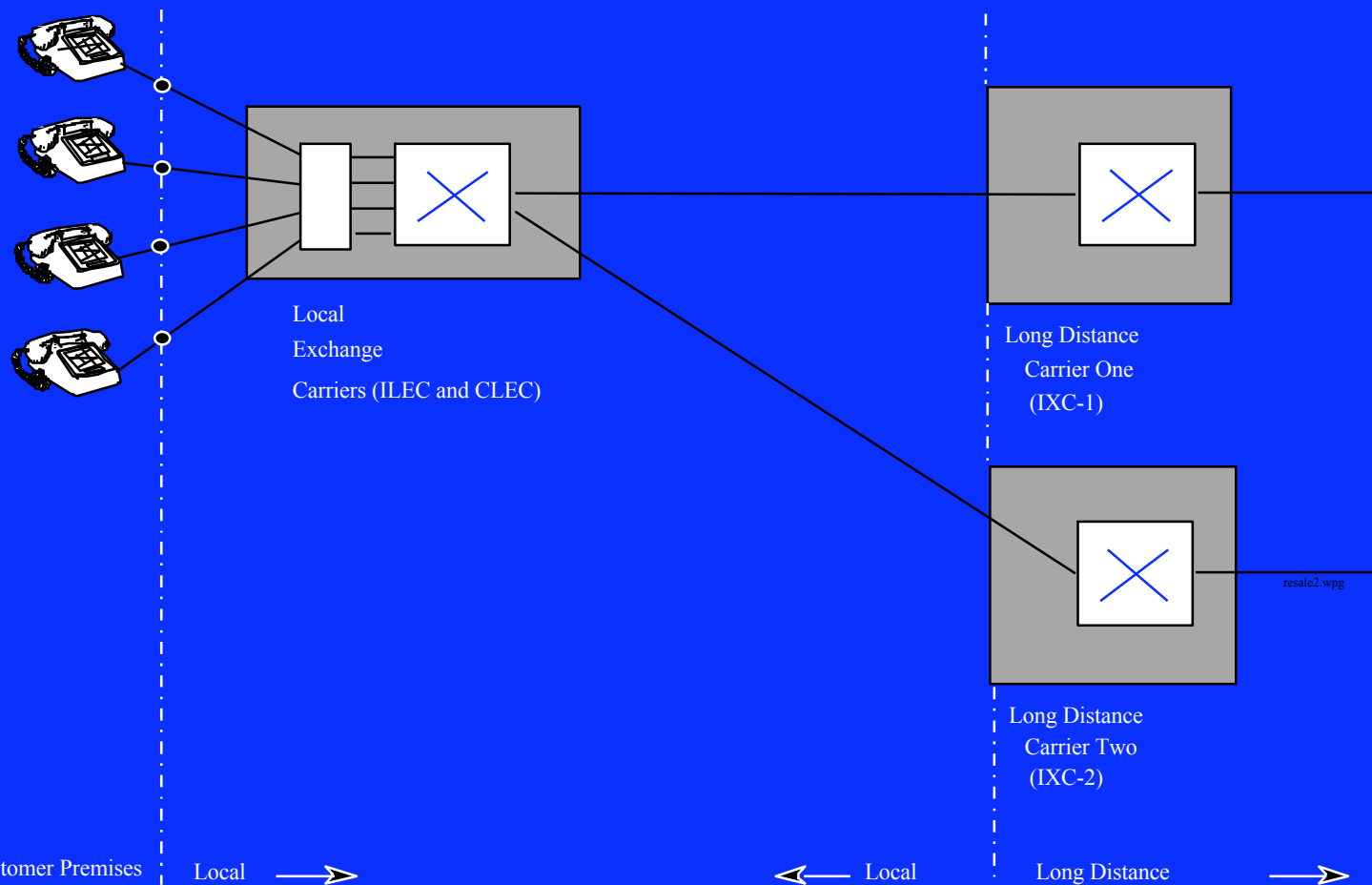

The Traditional PSTN

- Facilities-Based Local Exchange Competition

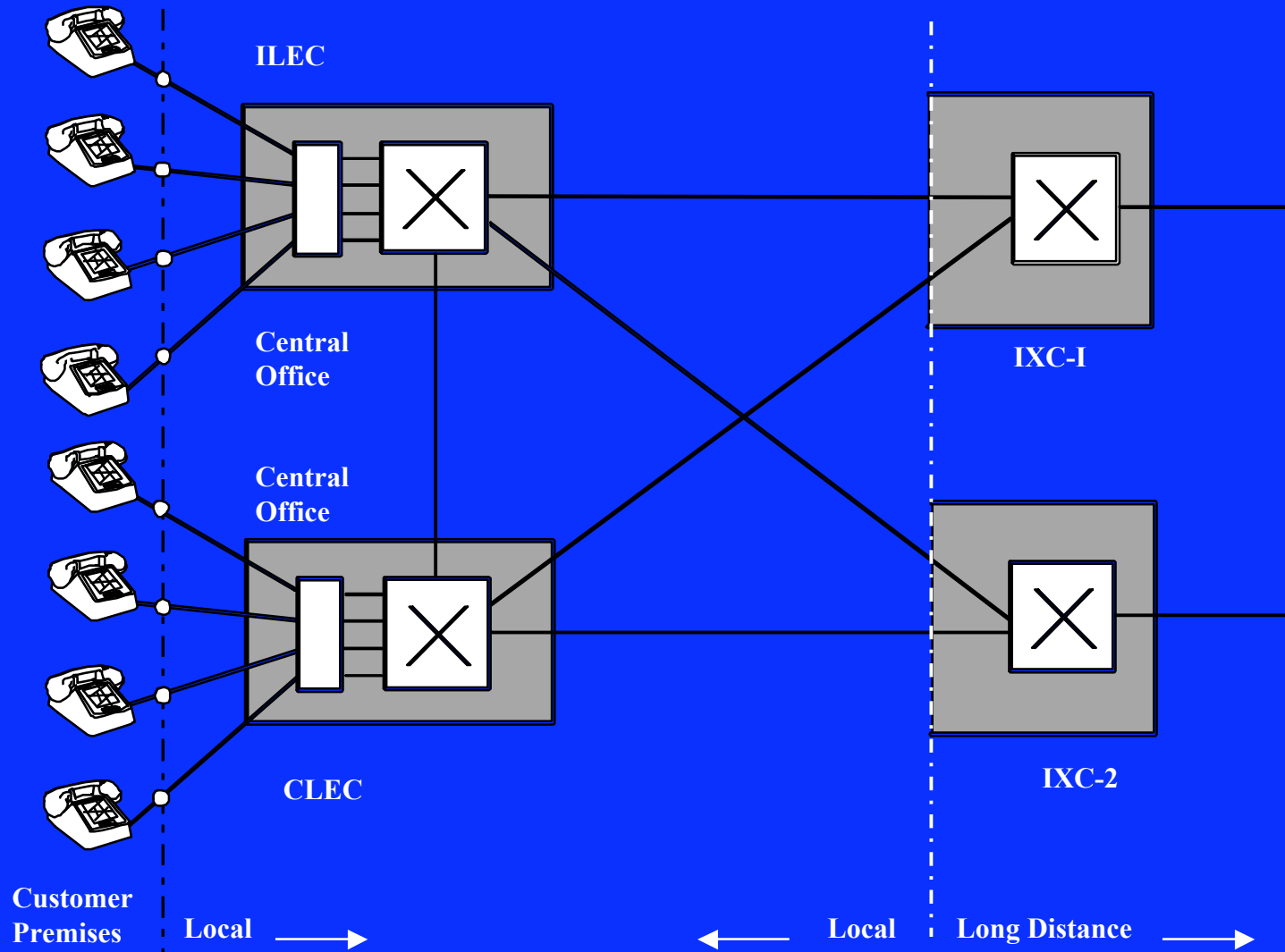

The Traditional PSTN

- Unbundled Network Element-Based Local Exchange Competition (Unbundled Loops)

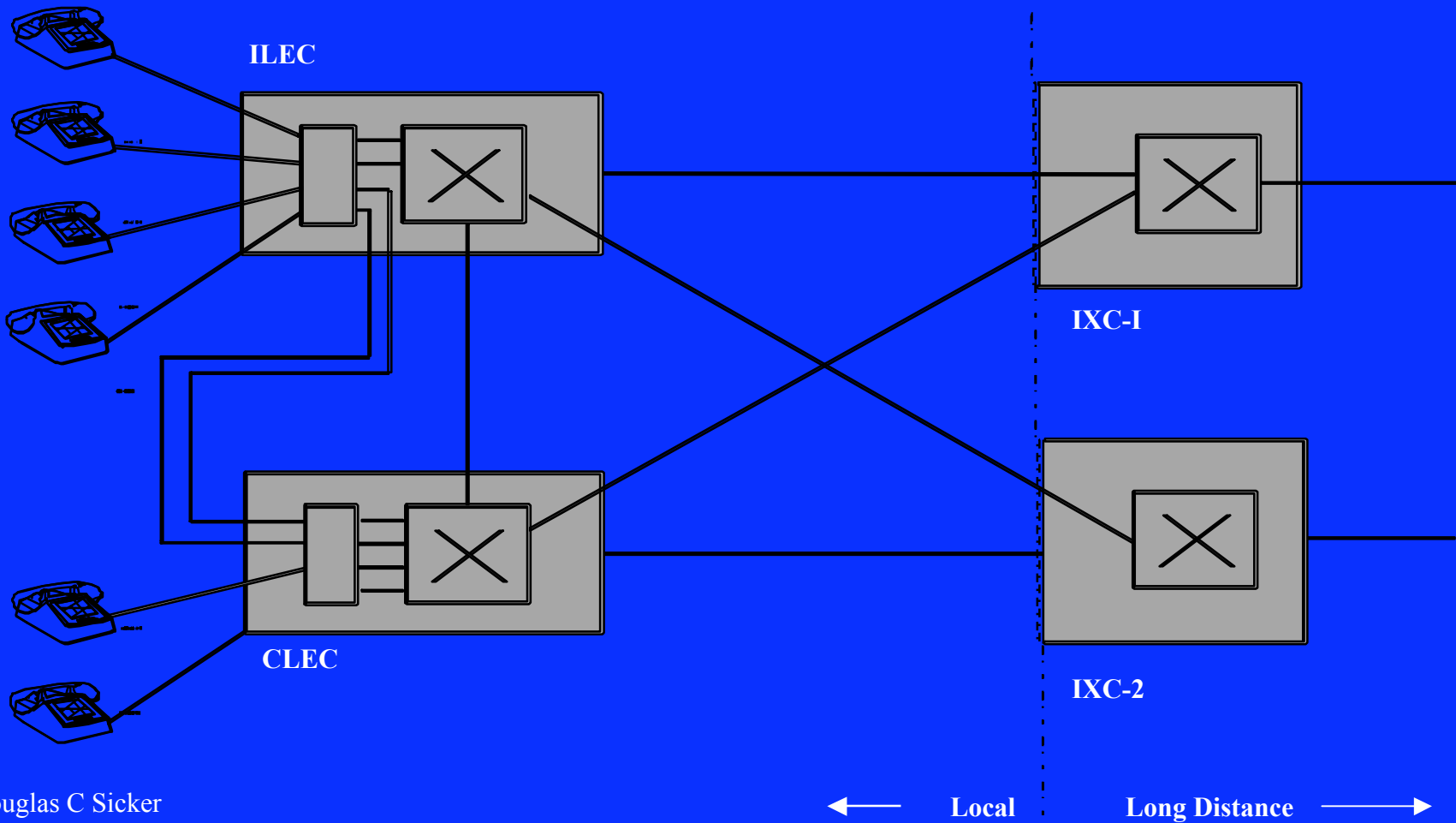

The Traditional PSTN

- Switched Versus Special Access

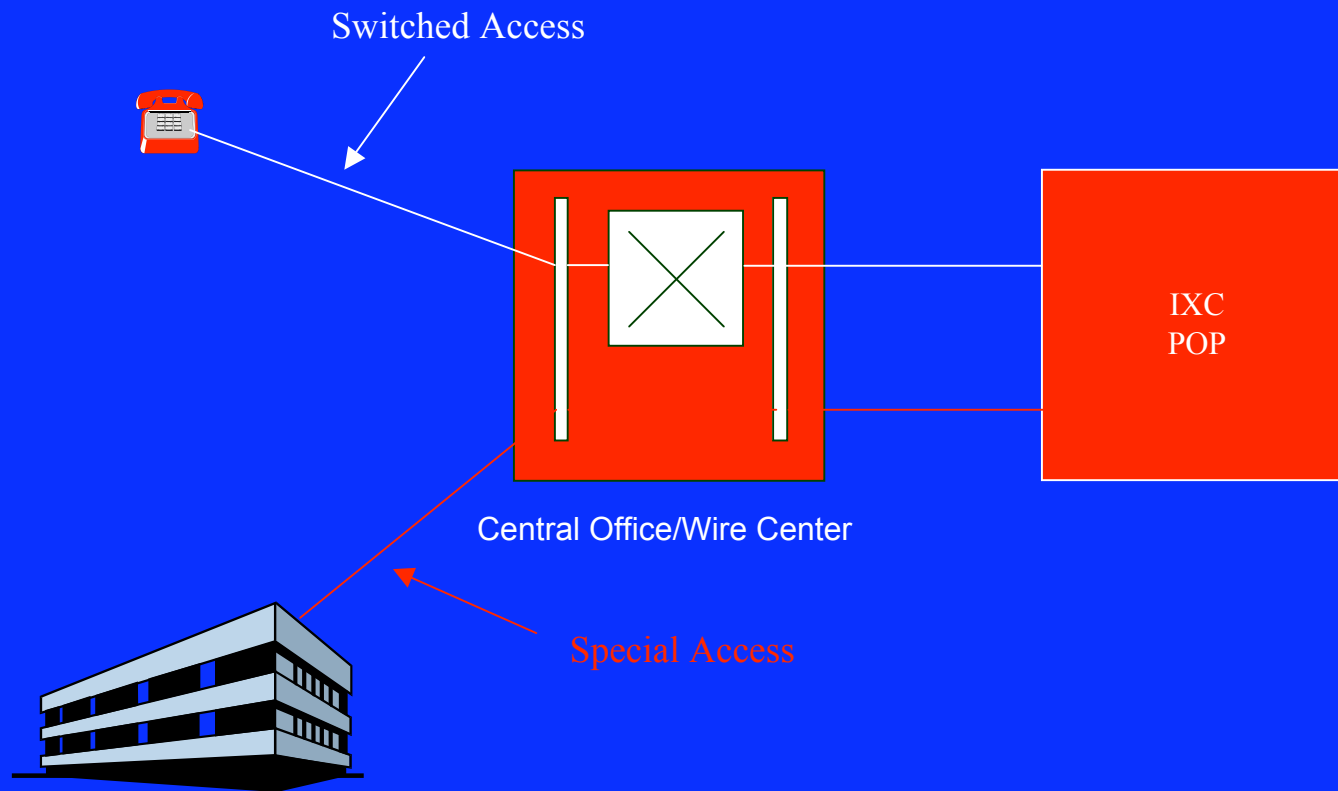

The Traditional PSTN

- Special Access -- Details

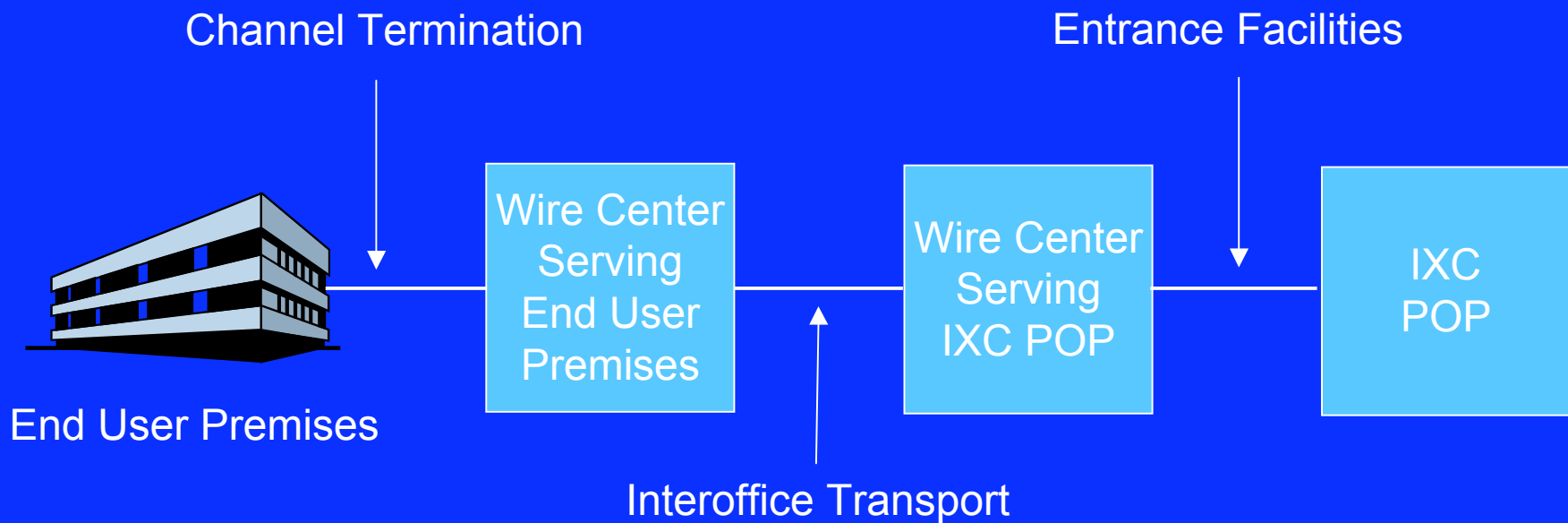

Traditional Cable Television Network

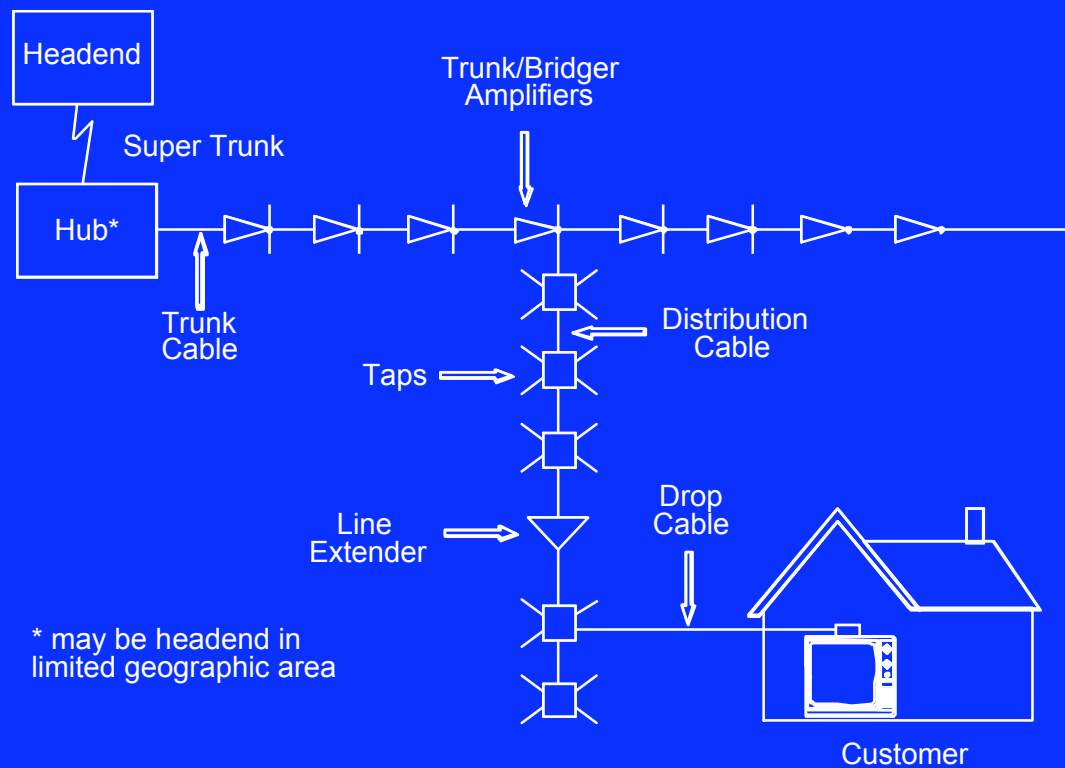

Traditional Wireless Network

- Traditional Cellular Network

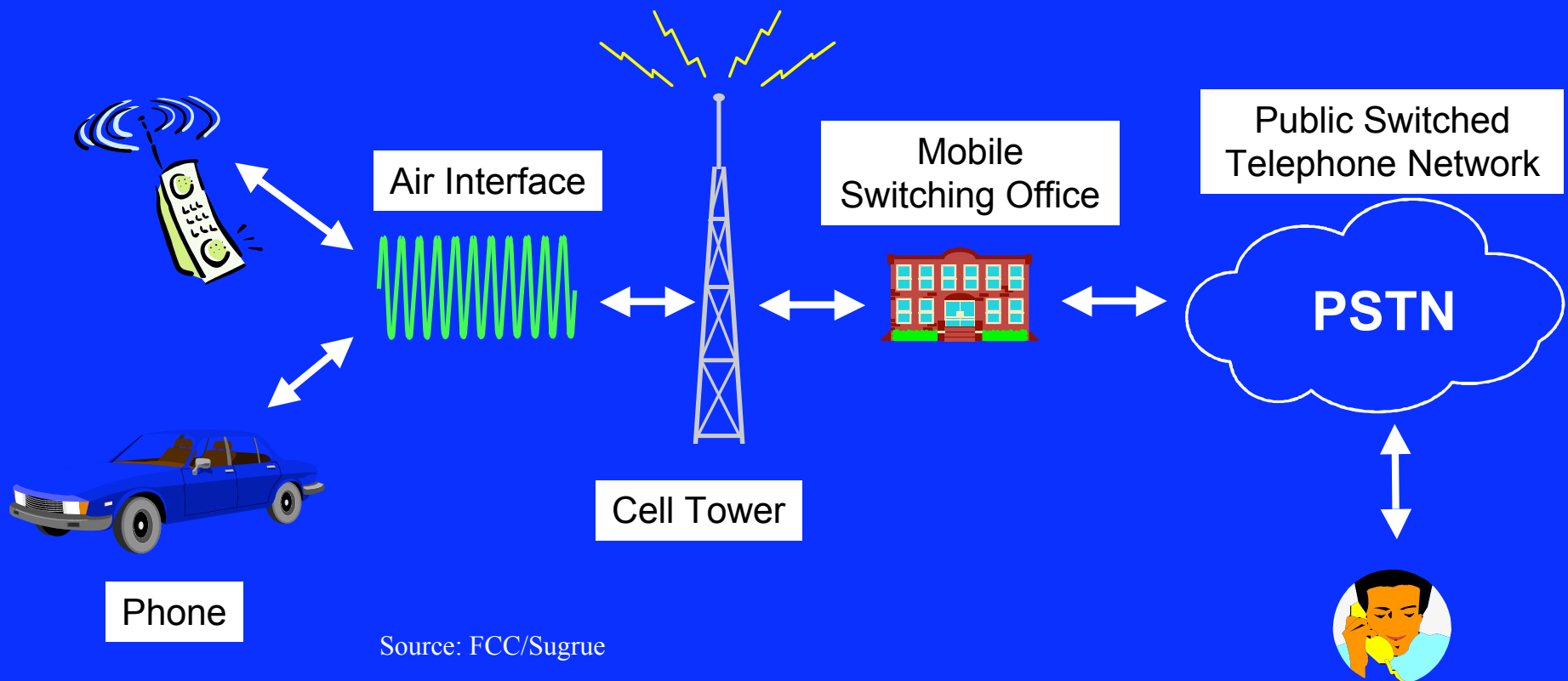

Evolution of the Traditional Networks

Evolution of the Traditional Networks

- Observations Regarding Traditional Voice, Data, Cable and Wireless (Cellular) Networks
 - Individually architected to match the characteristics of the three types of signals (voice, data, entertainment video)
 - A result of the tight coupling between the architecture/network design and the applications was technological “stovepipes”

Evolution of the Traditional Networks

- Observations (Continued)
 - These specialized networks or technological stovepipes were “unconverged” as opposed to being general purpose or converged platforms capable of handling voice, data, still image and video – multimedia
 - The regulatory structure (both the governing law and the organization of the regulatory agency) reflected (and still reflect) these technological “stovepipes”

Evolution of Traditional Networks

- Traditional “Silos” of Service/Regulation



Evolution of the Traditional Networks

- Observations (Continued)
 - All of the traditional networks are developing in a similar direction from a network architecture standpoint:
 - Evolving from analog to end-to-end digital transmission and switching (largely completed except in the “last mile”)
 - Extending broadband facilities deeper into the network either directly to customers or closer to them

Evolution of the Traditional Networks

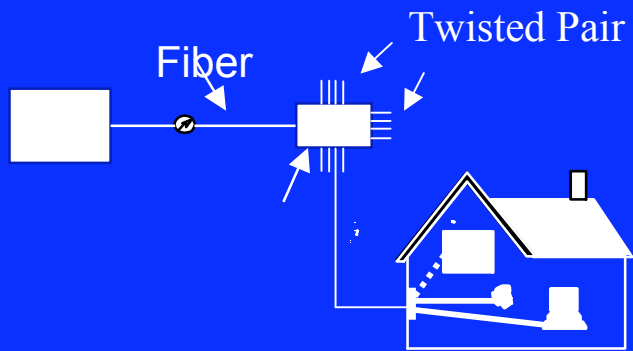

Wireline - DSL

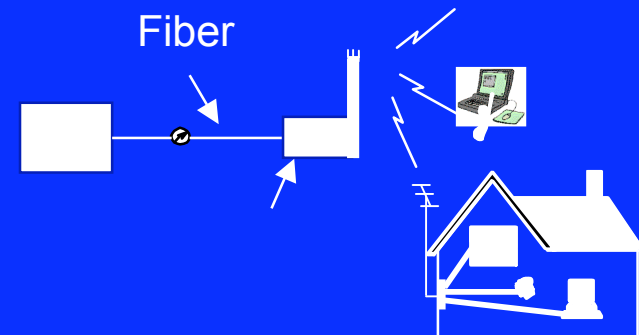

Wireless – Various

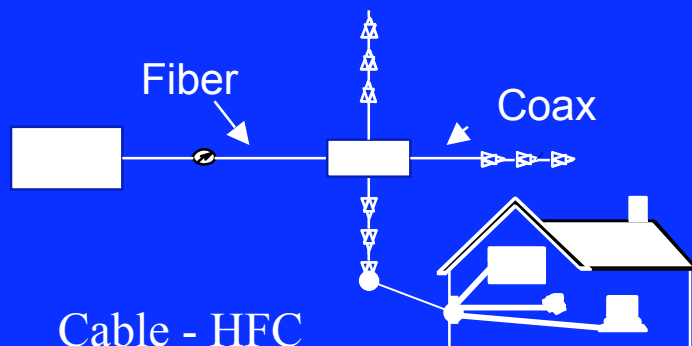

Cable - HFC

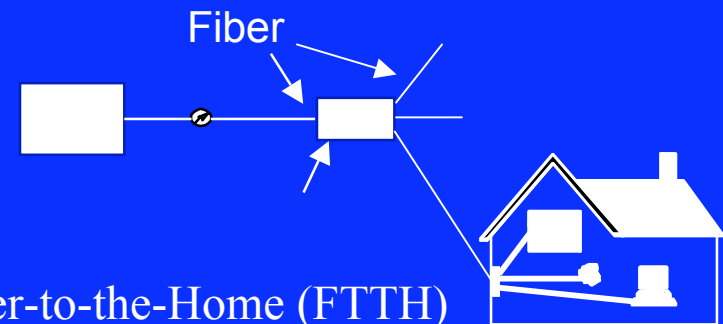

Fiber-to-the-Home (FTTH)

Evolution of the Traditional Networks

- Observations (Continued)
 - Evolving from circuit switching to packet switching with more “intelligence” at the edge of the network rather than the interior
 - Logical separation of the signaling and transport portions of networks – i.e., separation of control information from user content – and the development of more powerful signaling/control systems accessible to end users and third party providers
 - The above two steps rely heavily upon the Internet Protocol Suite (TCP/IP)

Evolution of the Traditional Networks

- The Result of the Trends:
 - “Technological convergence” and the creation of a powerful all digital, packet-switched, broadband, low latency platform supporting all applications – voice, data, image and multimedia
 - A “network of networks” platform that uses common, open, non-proprietary standards and protocols (i.e., the Internet Protocol -- IP)
 - Extension of this platform using wireless technology to allow users to communicate anyplace, anytime, in any mode or combination of modes

Evolution of the Traditional Networks

- Future Converged Services

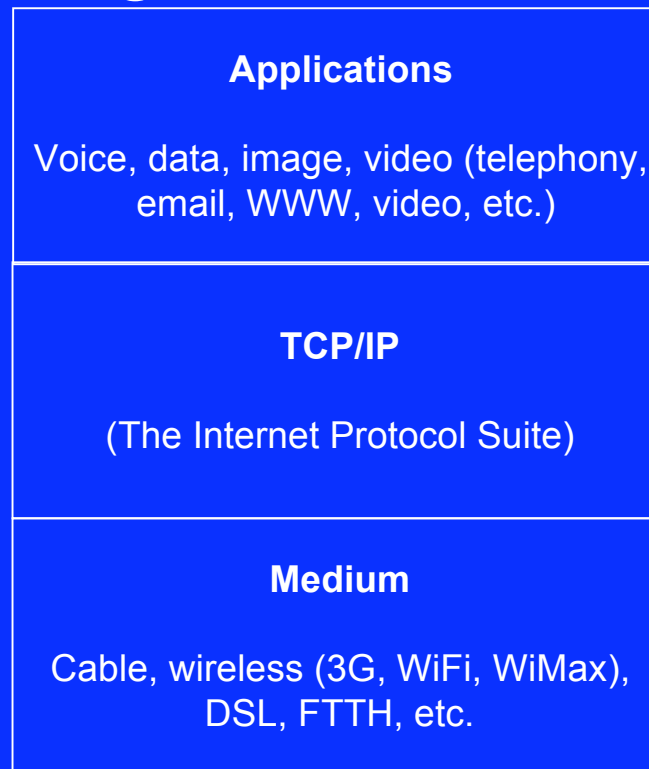

Evolution of the Traditional Networks

- Integrated Network with Integrated Access

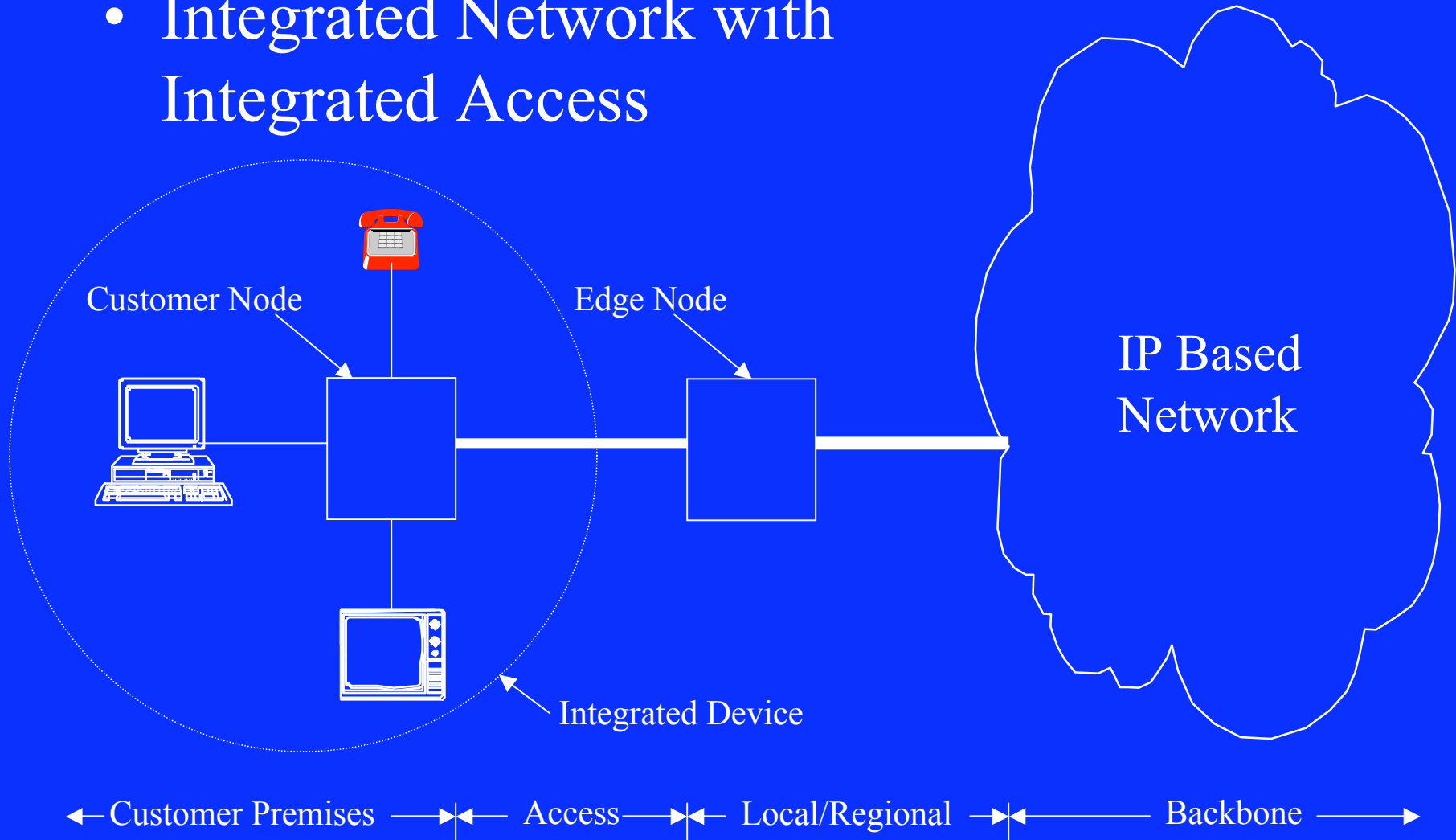

Public Policy Implications (Illustrative)

Source: Sicker/Hatfield

Public Policy Implications (Illustrative)

- Administration/control/regulation of functions that should be centralized
- Definition of what qualifies for universal service support
- Definition of what services should contribute to the universal service fund

Source: Sicker/Hatfield

Public Policy Implications (Illustrative)

- Boundary between telecommunications and information services
- Boundary between cable and broadcast and telecommunications services
- Structure of regulatory agencies
- Access charges and intercarrier compensation

Public Policy Implications (Illustrative)

- Jurisdictional Issues
 - Definition of telephone service when it is just an application residing in computers at the edge of the network
 - What should be regulated?
 - Who should be the regulator?
 - How is it to be regulated?
 - How do we ensure social goals?
 - Who should be responsible for consumer issues?

Contact Information

Douglas C. Sicker, Ph.D.

Director of the ITP Labs and Assistant Professor
Computer Science

Interdisciplinary Telecommunications Program

UCB 430

Boulder, CO 80309

douglas.sicker@colorado.edu

<http://spot.colorado.edu/~sicker>

303-735-4949