

Electricity Storage in T&D Applications



Larry Dickerman
American Electric Power

February 2009



Challenges to Our Business

- Intermittent nature of renewable DG such as wind on AEP grid
- Increasing demand for improved service quality and reliability
- Future PHEV load
- Cost control
- Improving use of assets
- Improving efficiency (internal & customers)

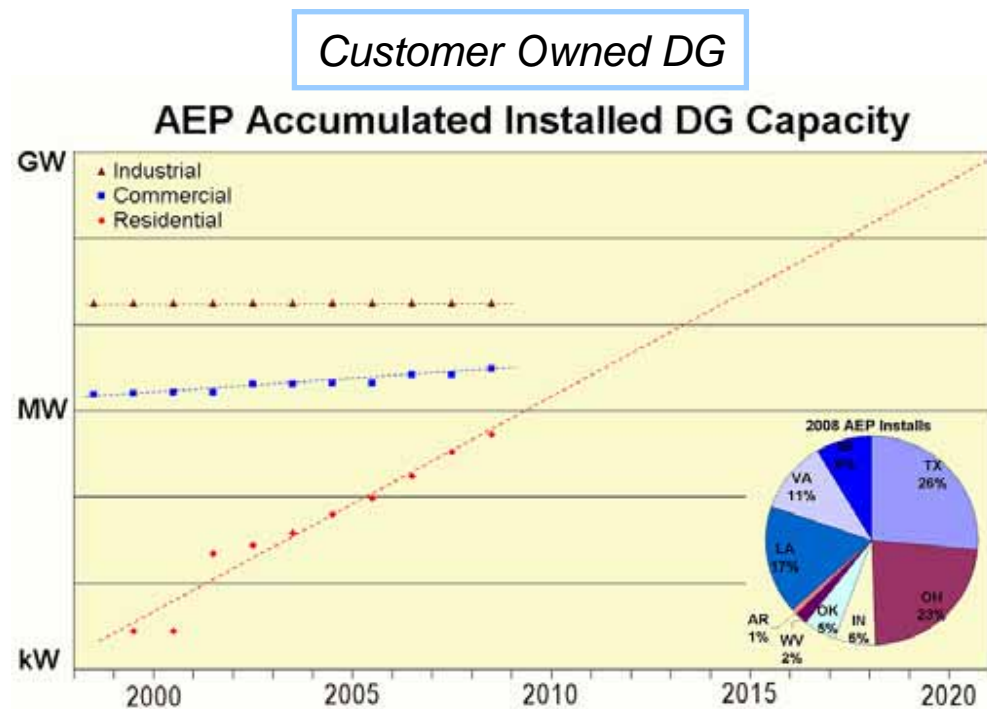

AEP 2006 Project – Battery in an Existing Substation

- Installed **1MW, 7.2 MWh of NAS** battery on a feeder to defer building a new substation for three years
- Daily Peak Shaving –summer
- Three years of successful operation

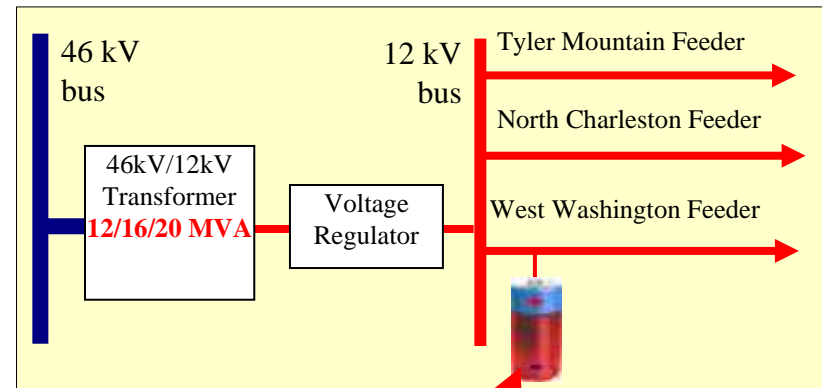

Energy Storage – Multiple Benefits

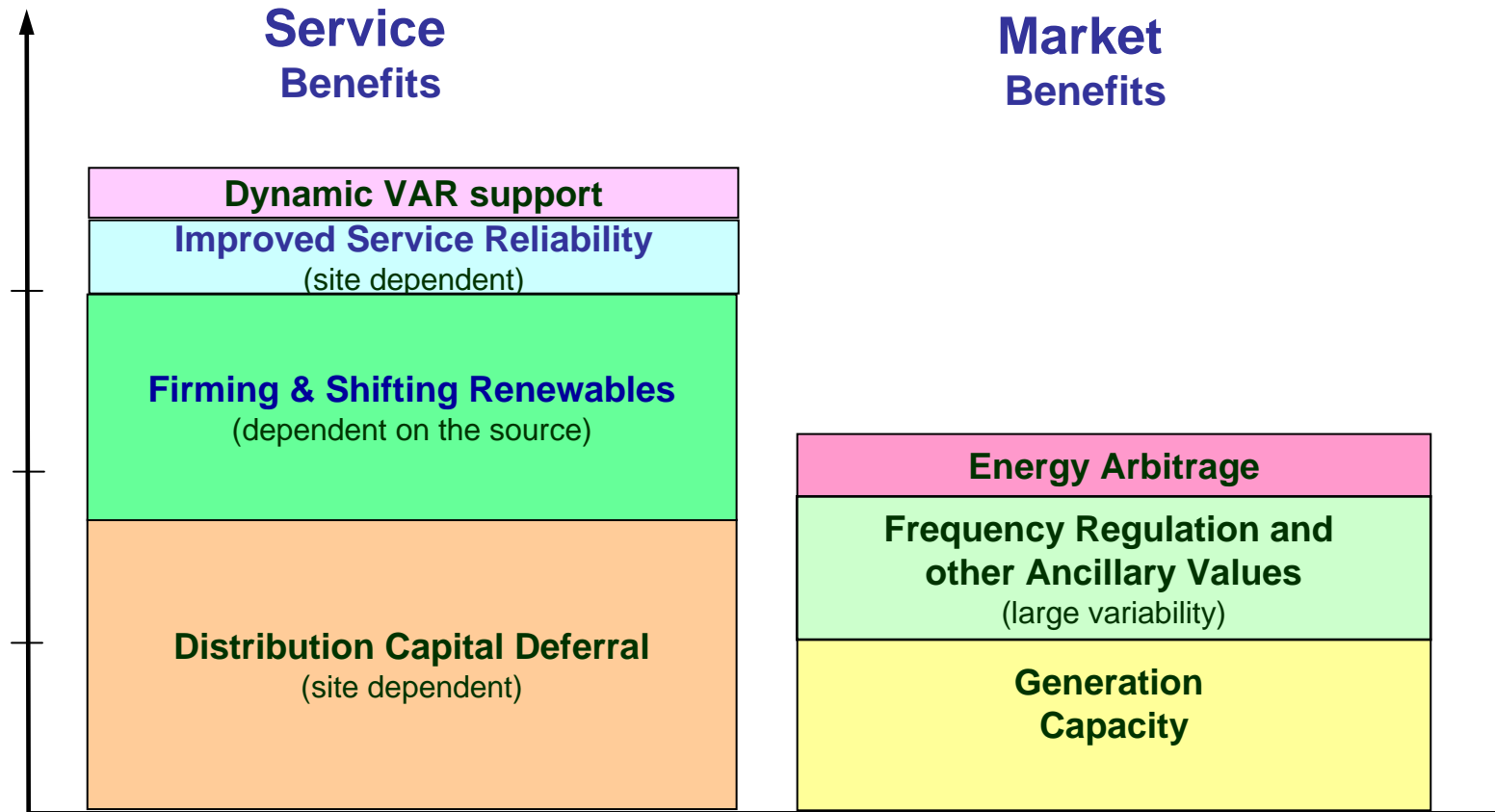

values are based on studies made for an AEP site



2008 Projects – To Improve Service Reliability

- 2MW, 14.4 MWh in Bluffton, Ohio
- Two other identical sites in West Virginia and Indiana (2008)
- All with dynamic islanding

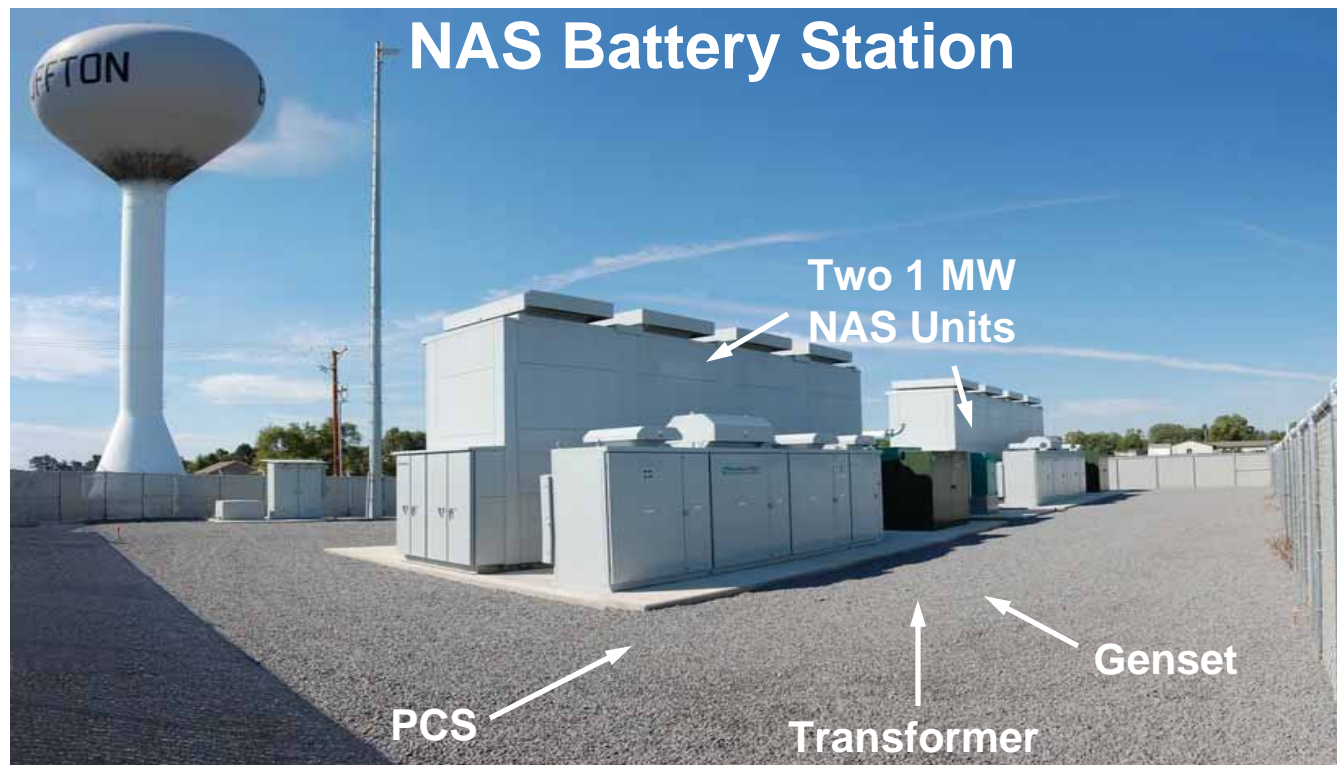

Community Energy Storage (CES)

A Game Changer



Community Energy Storage (CES)

CES is a small distributed energy storage unit connected to the secondary of transformers serving a few houses or small commercial loads for:

- Better service reliability and T&D efficiency (close to customers)
- Voltage sag mitigation and transformer load relief
- Multi-MW, Multi-hour service *to grid when aggregated*, (leverage AMI¹)
- Potentially low cost and high reliability (synergy with PHEV²)
- Buffers customer DG and PHEV impacts

Padmounted Transformer

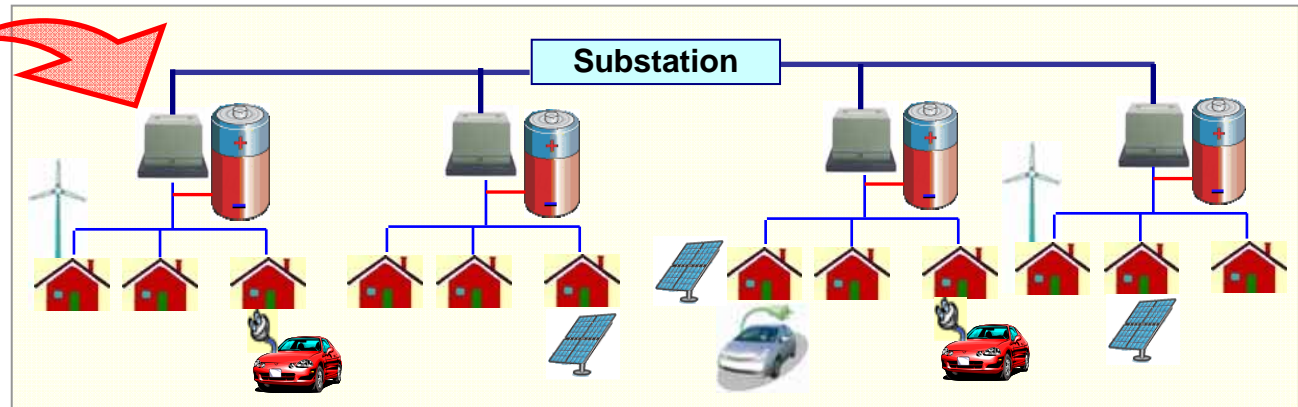

1- AMI = Advanced Metering Infrastructure
2- PHEV = Plug-in Hybrid Electric Vehicle

Barriers to Implementation of Storage

Economic

- Cost of storage
 - Need volume & competition
 - Incentives to industry
- Being able to capture multiple values in a given application

Regulatory

- How to handle multiple benefits across distribution, transmission and generation?
- How to handle energy in and out in a deregulated environment?